

ACT-01

VAG Chain Tensioner Locking T handle

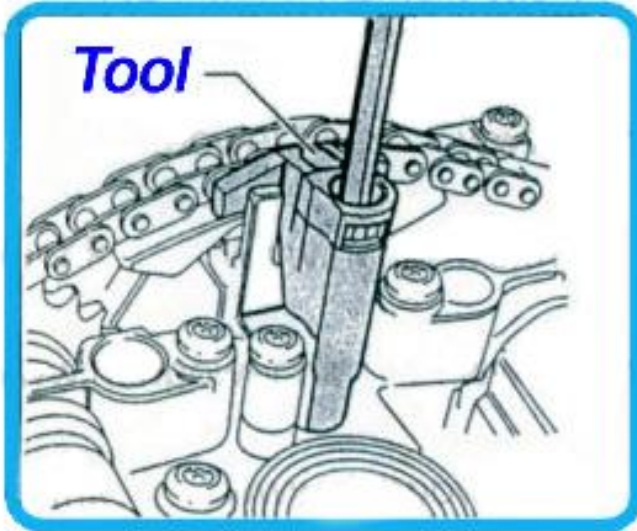

Material: PA66+30%GF W/M6x1.0 Screw black Finish

To lock the chain tensioner.

**For AUDI - AHA, AMB, AMU, APB, ART, ATC, ATQ, AWM, AWN, AWP, BBD, BCY, BEA, B
VW - AHA, APH, ATQ, AUG, AWM, AWP, AWV, BKF, BNU 1998-2006**

Packing: Sliding card

100pcs/8/9/1.3'

ACT-01

ACKT-01

VAG Chain Tensioner Locking T handle





Material: Cr-V steel Black finish

Size Length

Inner hole $\varnothing 30\text{mm}$?

To removing and re-fitting copper washer in the injection engine.

Packing: BMC

24pcs/14/15/1'

ATR-513-131P

131PCS Thread repair and workshop kits



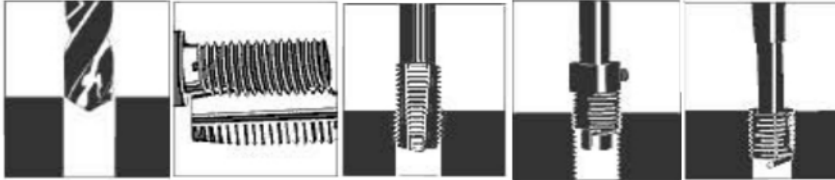

Material: Cr-V Steel FINISH:Black finish
Suitable for engines repair and broken thread .
Ideal for thread resistance.

Contents:

Thread Insert:Stainless steel.

C o n t a i n s :	
2 5 - M 5 x 0 . 8 x 6 . 7	7 m m 5 - T w i s t d
2 5 - M 6 x 1 . 0 x 1 0 . 8	5 m m B r e a k i n g
2 5 - M 8 x 1 . 2 5 x 1 0 . 8	m m s c r e w
2 5 - M 1 0 x 1 . 5 x 1 3 . 5	m m i n s t a l l e
1 0 - M 1 2 x 1 . 7 5 x 1 6 . 3	m m
1 - H e x k e y 2	m m

Packing: Steel case W/Tray

10set/20.5/21.5/1.2'

E2868

3pcs Seam Buster & 90 degree angle seam buster & Double seam buster



SB-01

SB-02

SB-03

Seam Buster

Easily Separate Spot Welded or Bonded Panels

- Save up to 15 minutes per panel replacement.
- For quarter panels, rockers and any other pinchweld.
- Sharpened on two edges. The sharp end allows for penetration between the panels and the side edge allows for side impact to drive the panels apart without damage.
- Cushioned handle absorbs shock.
- Super tough alloy steel.



Material: SCM440 steel.

Size Length

SB- 01	300mm
SB- 02	90 degree 250mm
SB- 03	300mm

Packing: BMC

20pcs/20/21/1.2''

AS-3814250-12P

Extra long Spark plug socket



Material: Cr-V Steel 3/8"Dr. Length:250mmL

Size:14mm x12PT

Feature:

One piece forged Cr-V Steel.

Special Thin wall

For Citr en C5 HPI,Peugeot 406 HPI,Mini one.

Packing: Polybag

50pcs/16/17/0.6''

AS-3814250-12P

Extra long Spark plug socket





Material: Cr-Mo Steel FINISH:Black

Suitable for truck repair e.g. cylinder head bolts, balance wheels and vibration shafts

Contents:

3/4"Dr. *110L

2pcs Impact socket 12PT :17,19mm
4cs Impact E socket:E18,E20,E22,E24
SW 17- MAN/MB-LKW 400/420/500
SW19-MB-LKW 300/400/900 Actros
E18-MAN Mod.M2000,Buses Motor D08
E20 –MAN F2000,F90,F8,Buses Motor D25/D28
E22-Gernal Truck
E24-MAN

Packing: BMC
6set/20/21/1'

APR-3PCS

3pcs Glow plug puller and reamer kit set



Contents :

- 1 – Glow plug puller $\varnothing 9$
- 1 – Reamer for 8mm glow plug $\varnothing 6$ M1 \varnothing x1.5P
- 1 – Reamer for 10mm and 12mm glow plug $\varnothing 7$. 3M1 \varnothing x1.75P

Features :

-????? For removal of stubborn glow plugs.Reamers supplier for cleaning the glow plug apertures.

- **Packing : BMC** 20sets/13/14/1.2'

SP-645~647

3pcs Lock ring plier(External type)



P-645



P-646



P-647



Material:Cr-V(6140) Chrome plated matt finish HRC 44-48

P-645 Bent tip 90 For outside lock rings (shafts), gear boxes

P- 646 Straight tips For outsi

P- 647 Be Fit d ip s p a d n s f s a d g a b o e s W T 4 a n d T 2

Design especially for easy removal and replacement of clip ring

Length:200mmL

Packing: Box

24set/19/20/1.3'

BPP-01

E-Z Pull Exhaust pipe Pat.

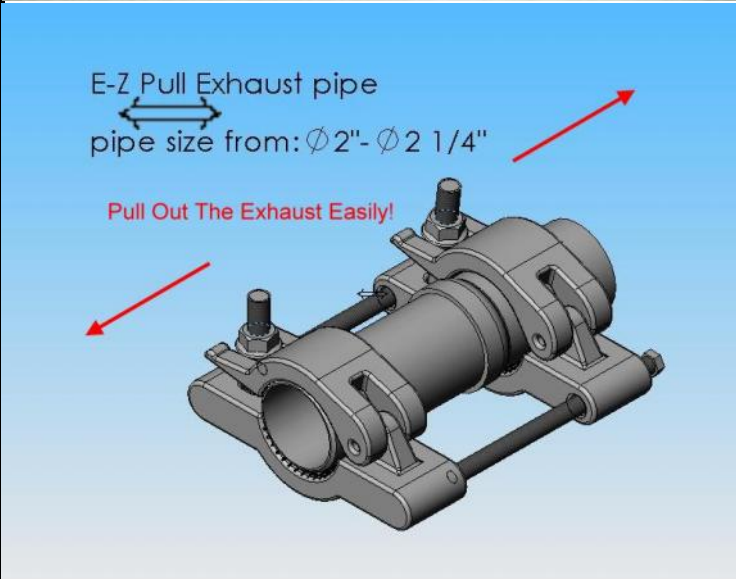

Material: Drop forged SCM440 steel

Design especially for providing pull out the exhaust pipe easily. Special design way for use with 17mm open wrench and 3/8" Dr. ratchet wrench to adjust bolt t out the nine . Save your time

Out the pipe . Save your time.

Size Length

2" to 2- 1 / 4"

Suitable for:Exhaust pipe.

Packing: BMC

5sets/20/21/0.8''

BP5-3PCS

3pcs 1/2"Dr.Pentagon Socket



Material: CR-V Steel PH Black Finish

Bit material:S2

Size	Length		
1 / 2 " D r . * 1 0 m m	P e n t a g o n b i t	5 6 m m	f c
1 / 2 " D r . * 1 4 m m	m a l e t y p e	3 8 m m	f
1 / 2 " D r . * 1 9 m m	m a l e t y p e	3 8 m m	f

Ci troën ,Peugeot ,Renault

Packing: BMC

40sets/14/15/1.2''

SIST-6PCS

3/4"Dr.Impact bits B&S-XZN





Material: Cr-Mo Steel

Suitable for truck and car repair e.g. cylinder head bolts, balance wheels and vi shocks; with easy change replaceable bits (Bits are fixed by a screw and are exchangeable), allen key included..

Contents:

4pcs Impact bit: M12, M14, M16, M18 107mmL

1pcs Impact socket: 3/4" Dr. *H22

1pcs H4 Hex key

M12 Rear hubs Touran

M14 for 500 series since 12/1995, 900 since 06/1996, rear hubs L/T Transporter

M16 Rear hub on Sharan

M18 Rear Hubs on Golf

Packing: BMC

10set/22/23/1'

SIST-16PCS

3/4" Dr. and 1" Dr. Impact bits and E sockets set







Material: Cr-Mo Steel

Suitable for truck repair e.g. cylinder head bolts, balance wheels and vibration s
with easy change replaceable bits (Bits are fixed by a screw and are
exchangeable), allen key included..

Contents:

9pcs Impact bit: T60, T70, T80, T90, T100, H17, H19, H22, H24 107mmL

4pcs Impact socket : E18, E20, E22, E24 107mmL

2pcs Impact socket: 1"Dr.*H22 , 3/4"Dr.*H22

1pcs H4 Hex key

Packing: BMC

3set/18/19/0.66'

SBS - 3460-09

9PCS 3/4"DR. Impact bit socket



Material: Cr-Mo Steel FINISH:PH Black

Suitable for truck repair e.g. cylinder head bolts,balance wheels and vibration sh

Contents:

3/4"Dr. *60L

7cs Impact Hex Bit socket:H14,H17,H19,H21,H22,H23,H24

2pcs Impact Spline socket:M16,M18 W/Tamperproof

Packing: BMC

6set/18/19/1'

SBS - 3460-6T

6PCS 3/4"DR. Impact bit socket



Material: Cr-Mo Steel FINISH:Chrome plated

Suitable for truck repair e.g. cylinder head bolts,balance wheels and vibration sh

Contents:

3/4"Dr. *60L

4cs Impact Torx Bit socket:T70,T80,T90,T100

2pcs Impact Spline socket:M16,M18 W/Tamperproof

Packing: BMC

10set/22/23/1'

SBS - 3460-06H

6PCS 3/4"DR. Impact bit socket



Material: Cr-Mo Steel FINISH:Chrome plated

Suitable for truck repair e.g. cylinder head bolts,balance wheels and vibration sh

Contents:

3/4"Dr. *60L

6cs Impact Hex Bit socket:H14,H17,H19,H21,H22,H23

Packing: Steel case W/EVA

10set/22/23/1'

EAW-01~05

5pcs Plastic assembly wedge set/Bodywork tools





Material:PA6+GF 30%

Item no.		Length(LxW)
AW-01	Assembly wedge"Uni"	190x30mm
AW-02	Assembly wedge with felt surface	250x20mm
AW-03	Assembly wedge "Spiky"	250x20mm
AW-04	Assembly wedge"Uni wide"	190x60mm
AW-05	Assembly wedge "Special level"	230x30mm

For fast and easy removing of mouldings and door covering,application of plugs and plastic clips,avoids damage of lacquered surfaces,plastic and metal parts;AW-02 one side pointed,one with felt surface to fix plastic panels,cross section approx 20x20mm

Packing: color box

40set/11/12/1.3'

AARF-36PCS

Pat. Pending36pcs Folding type Radio Removal tool se





- P-01 Mercedes-Benz ,BECKER, VW, AUDI
- P-02 Mercedes-Benz ,BECKER ,Porsche
- P-03 VW
- P-04 Skoda New
- P-05 Becker New
- P-07 PK-Clari on
- P-08 RK-Kenwood O1
- P-09 Sony
- P-10 RK-Kenwood
- P-11-1 Flat, Bravo, Brava
- P-12 Pioneer & JVC
- P-13 Panasonic 2006

Feature:

1. Universal tool for installing and remove
2. (All applications in one tool)
3. Push button design to control holding t

Packing: Pouch 40sets/ctn/14/15/1.2'

ACE-70-2

SYSTEM - UNIVERSAL - TERMINAL RELEASE TOOLS

Specialty AUTO Repair Tool (w/worldwide PAT.)

- * CE-01+11: Ejection tools for round pin contact sizes 1.5mm(DIA.) w/diamantling sleeves for contact sizes.
- * CE-02+12: Ejection tools for round pin contact sizes 3.5mm(DIA.) w/diamantling sleeves for contact sizes. (BMW, DiamlerChrysler, Fiat, MAN, Opel, Porsche, Seat, Skoda, VW & Audi)
- * CE-05+15: Ejection tools for round pin contact sizes 2.3mm(DIA.) w/diamantling sleeves for contact sizes. (Ford, Opel, PSA, Renault)
- * CE-53: Cable extractor tool for flat plugs with one release channel 2.5 & 5.8mm (BMW, DiamlerChrysler, Ford, MAN, Opel, Porsche, Seat, Skoda, VW & Audi)
- * CE-56: Cable extractor tool for flat connectors Micro Timer II, III contacts 1.6mm(DIA.) (DiamlerChrysler, Opel, Porsche, PSA, Renault, Seat, Skoda, VW & Audi)
- * CE-59: for DUCON flat connectors Maxi-Power Timer contacts 9.5mm (DiamlerChrysler, VW/Audi)
- * CE-62: for flat connectors PIT-POD w/one snap-in pin at the connector & one in the housing (all vehicle makes)
- * CE-74: Cable extractor tool for Micro-Timer I contacts & ABS plug-in housing 1.6mm(DIA.) (Fiat, Ford, Mazda, Opel, PSA, Renault, Saab, VW & Audi)
- * CE-91: Cable extractor tool for flat plugs w/two release channels 2.8 & 5.8 mm (BMW, DiamlerChrysler, Fiat, Ford, MAN, Opel, PSA, Renault, Saab, VW & Audi)

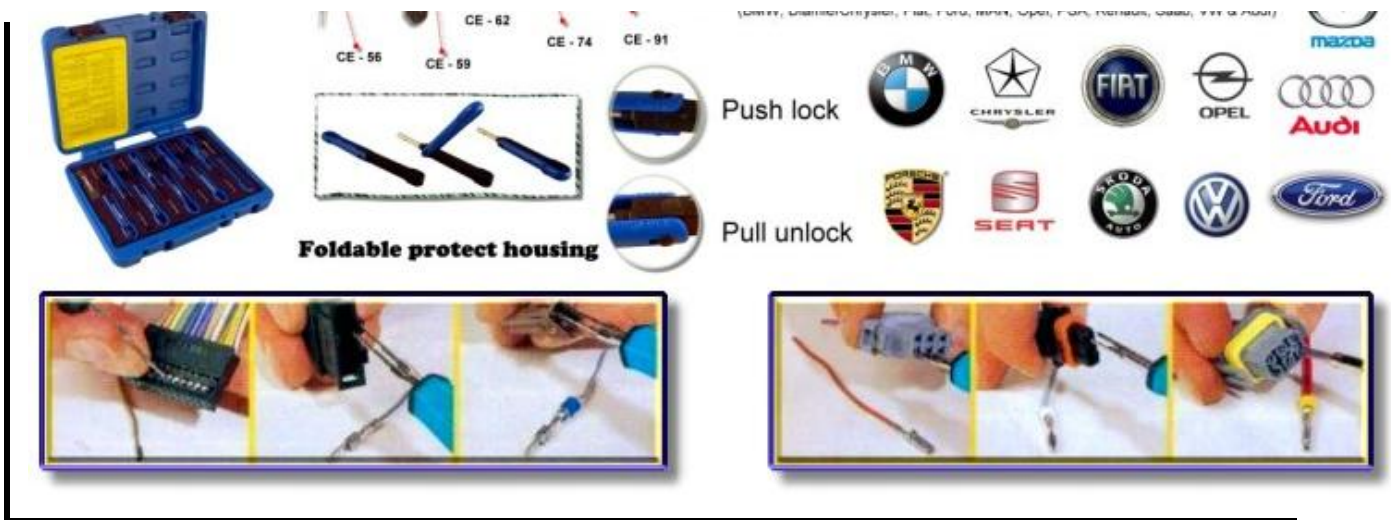

AI P- 3PCS



Injector puller with slide hammer

Material: Cr-Mo Steel

Total length:380mmL

Slide hammer:0.7KGS

Feature:

For removing of the seized injectors from the cylinder head.the special profile of the head fits around the injector,allowing easy and damage free removal.The head For Mercedes CDI engines OM 611,612,613 etc.

Packing: BMC

10sets/18/19/1.2''

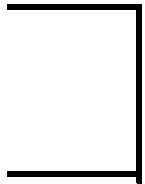

EL, BFM

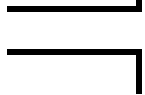

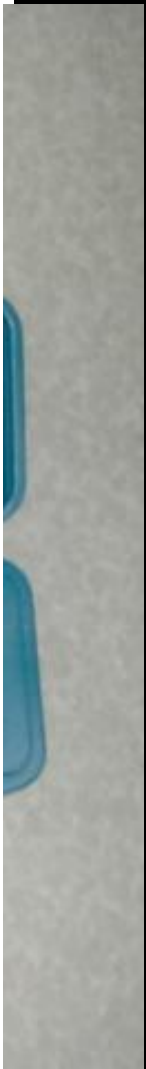

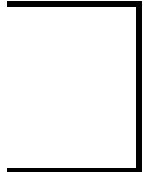
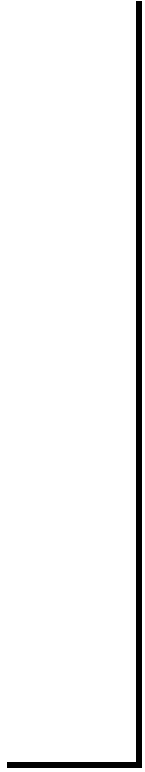



curve



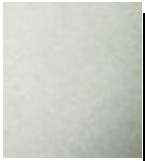

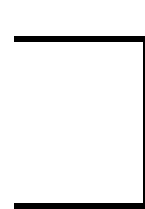



ocks;



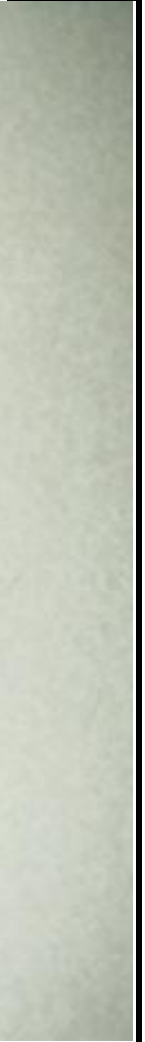
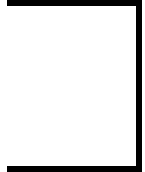
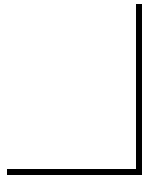

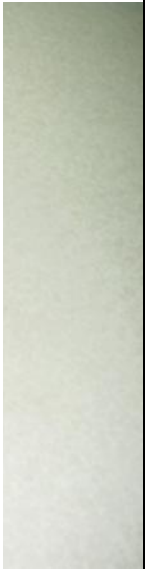
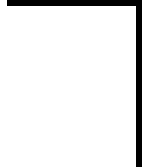
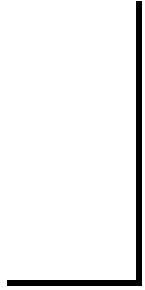

two
o pull

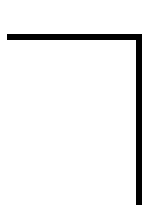
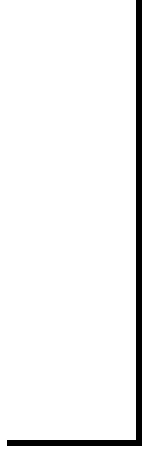
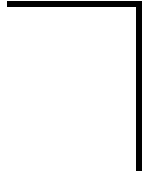
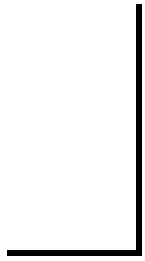



ibration

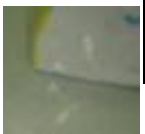





shocks;





ocks;



ocks;

ocks;

1

2

3

4

side

st

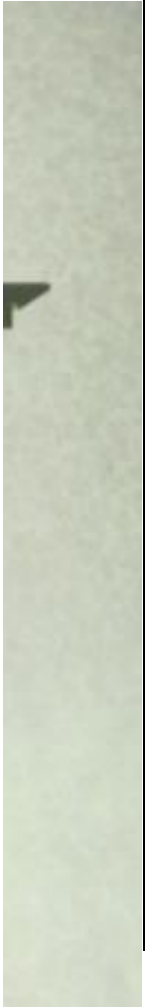

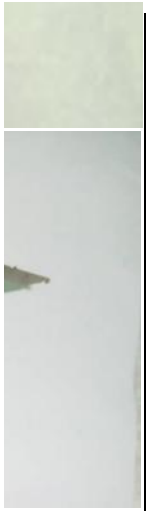



ad and slide spindle can be used separately.